

## We are DEVELON

DEVELON is powered by 88 years of trusted engineering expertise and proven quality.  
We transform this legacy into smart products and digital solutions that move the industry forward.

Built on trust and driven by innovation,  
DEVELON remains dedicated to maximizing customer value in the future.

Powered by **Innovation**



<https://global.develon-ce.com>

©HD Construction Equipment. All rights reserved.  
2026.04

Certain specifications may differ from actual results based on engineering calculations. Specifications are for comparison purposes only and are subject to change without notice.  
The specifications of individual DEVELON equipment may vary due to normal changes in design, manufacturing, operational conditions, and other factors. Some images of DEVELON equipment may show non-standard configurations.

# DEVELON

Construction Equipment

## DB100



# PRIDE AT WORK

DEVELON strives to build state-of-the-art earthmoving equipment to give every operator maximum performance, more precision, versatile machine preferences, and proven quality. Take pride in your work with a DEVELON!

## TIER 4 FINAL Certified Engine

- The DEVELON engine is EPA Tier 4 Final compliant with a 4-cylinder, 4-cycle, turbo-charged design, delivering power, reliability, and efficiency.

It features a robust aftertreatment system and a no EGR configuration for advanced emission control and simplified maintenance.

## EXCELLENT VISIBILITY

- One piece rounded wind shield for wide span of view.
- Well designed loader frame offers clear line of site and excellent visibility.

## SERVICEABILITY

- Tilt-up hood provides easy access to engine compartment.
- All greasing points are accessible from ground level for safety and reduced maintenance time.
- Integrated safety bar and lock system ensures operator safety.

## EXCELLENT BACKHOE PERFORMANCE

- Pilot controls provide the operator with better precision and control. (Optional)
- An extendable dipper significantly increases the machine's versatility. (Optional)
- Unique backhoe boom design provides good visibility.

## COMFORTABLE OPERATION

- Six pillared cab with ROPS / FOPS certified design for safe operation.
- Tilting, adjustable steering column.
- Hinged-type side windows for excellent ventilation.
- Conveniently located gauges, switches and levers for quick and easy use.
- Suspension seat with full adjustment for improved operator ride.

## POWERFUL LOADER PERFORMANCE

- Four wheel drive system designed for on-the-go activation improves loader performance in rough terrain conditions. (Optional)
- A strong and rigid loader frame designed for durability and greater lifting capacity.
- Automatic return-to-dig function reduces loading cycle times.

## ENHANCED HYDRAULIC MECHANISM

- Adjustable flow control system (AFCS) optimizes the travel power of the machine when traveling on the highway.
- Alternative pilot control pattern allows the operator to get the job done efficiently.
- Stabilizer safety system protects from both raises and lowers of the stabilizer.

\* Option spec info is included to the images contained in this material and may not be the same with the actual specs.

# OUTSTANDING PERFORMANCE

DB100 series provides the operator with best performance and productivity.



## TIER 4 FINAL CERTIFIED ENGINE

The DEVELON engine is EPA Tier 4 Final compliant with a 4-cylinder, 4-cycle, turbo-charged design, delivering power, reliability, and efficiency. It features a robust aftertreatment system and a no EGR configuration for advanced emission control and simplified maintenance.



## DURABLE AXLE AND BRAKES

Front & rear axles are designed for heavy duty to withstand the challenging Jobsite conditions. Outboard, planetary gears improve serviceability while multi wet disc type brakes eliminate possible external contamination. The parking brake can be easily activated from within the cab by the push of an electric switch.



## EXCELLENT BACKHOE PERFORMANCE

The backhoe is inherently strong design, perfect for heavy duty applications. The boom allows good visibility into the trench when the operator is digging around buried obstructions such as water mains, sewer pipes, utility lines, etc. Pilot controls(option) improve operator control and precision when excavating. And an extendable dipper as an option significantly increases the machine's versatility.



## WORK LIGHTS

Standard two front & two rear-adjustable 55 watt halogen work lights and optional four front & four rear-adjustable 55 watt halogen work lights provide excellent illumination at the work area.

Photo may include optional equipment.



### 1. FOUR WHEEL DRIVE (OPTIONAL)

Four wheel drive system improves mobility and loader performance in ground conditions underfoot and can be activated on-the-go.

### 2. RIDE CONTROL SYSTEM (OPTIONAL)

Ride control system is available for improved operator comfort. Ride control reduces bounce and shock when traveling on the job site. The system is designed to minimize loader lift bounce when traveling over rough terrain to reduce material spillage and improve travel with a full bucket. The operator can engage ride control by flipping the switch on the side console. Ride control improves job site productivity, operator comfort and overall safety.

### 3. POWERFUL LOADER PERFORMANCE

The DB100 series loader boom is integrally welded with a large diameter tube, dual lift and tilt cylinders for maximum strength and power. A strong and rigid loader frame allows for greater lift capacity, improved line of sight and overall visibility. The loader attachment can be equipped with automatic return to dig function as an option designed to reduce loading cycle times.

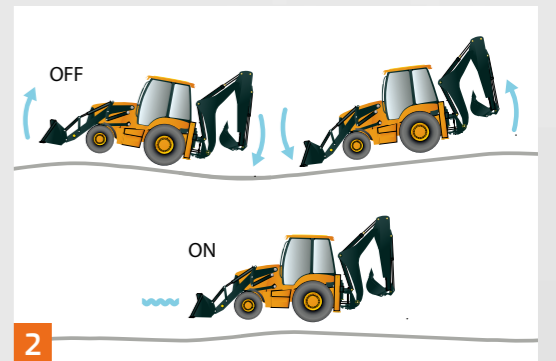

3

2

# ENHANCED HYDRAULIC MECHANISM

Innovative hydraulic technologies make the DB100 series fast, smooth and easy to control.



## CONTROL PATTERN SELECTOR (OPTIONAL)

The control pattern selector switch, located in the cabin, allows the operator to change from the excavator ISO control pattern to the backhoe SAE control pattern for the backhoe simply by pressing a button. This allows the operator to use the accustomed pattern they are familiar with to get the job done efficiently.

## ADJUSTABLE FLOW CONTROL SYSTEM (AFCS)

By using the "turtle" switch ("turtle" for low speed attachment control) on the front instrument cluster, the operator diverts any unused hydraulic fluid from the second pump to the hydraulic reservoir. In a loader application, AFCS optimizes the travel power of the machine and improves productivity. AFCS is also useful when traveling on the road.



## CLAM SAFETY SYSTEM (OPTIONAL)

Prevents the uncontrolled opening of the clam bucket by its weight of load during both loading and dozing processes.



## STABILIZER SAFETY SYSTEM

Two stabilizers and two stabilizer safety valves are equipped (each operated by its own control valve and cylinder). They provide protection in the event of a hose burst in both stabilizers. Also, they protect from both raises (while working) and lowers (while traveling) of the stabilizer.

# COMFORTABLE OPERATION

## You are at the Center of Comfort and Control

DB100 series backhoe loaders are designed for the operator's comfort. The steering column and backhoe control tower can be tilted and adjusted for convenient operation. Deluxe, joystick levers, conveniently located switches and an AM/FM radio with mp3 input provide the pleasant operation. Hinge-type side windows can be opened for improved ventilation. Additionally, front and rear windshield wipers are equipped for excellent visibility during bad weather conditions.





\* Option spec info is included to the images contained in this material and may not be the same with the actual specs.

#### COMFORTABLE OPERATOR'S CABIN

The DB100 series cab is designed to offer maximum comfort, safety and low noise to the operator. The cab structure is supported by six pillars meeting ROPS/FOPS safety requirements. The cab also offers dual entry, deluxe trim, tilt steering column and a washable molded floor mat. Large roomy cab space and rounded glass contribute to operator comfort. Adjustable seat for a wider operating range and more comfortable ride. Equipped with seat cushion extension, seat cushion tilt, and vertical angle adjusting armrests.

#### CLIMATE CONTROL SYSTEM (OPTIONAL)

A full heating, defrosting system keeps the operator comfortable with 15 air vents placed throughout the cab. Air conditioning system as an option well placed air vents within front, back and sides of seat provides operator with optimum temperature.

#### PILOT CONTROL SAFETY SYSTEM (OPTIONAL)

Disables the control lever of loader, backhoe (excavator), and stabilizer levers by flipping the safety switch on the side console



Safety Switch (Loader)    Safety Switch (Backhoe)

#### POWER BOOSTED BRAKE (OPTIONAL)

Newly developed Boosted Brake System now allows the operator to use brake much conveniently with additional hydraulic assisted power.

#### BRAKES

Oil immersed wet disc brakes are individually actuated by two separated brake pedals. Brakes are self adjusting for improved service life.

#### POWER SHIFT TRANSMISSION

Standard power shift transmission provides fast, easy and efficient operation. A convenient gear/shift selector allows for gear selection and forward, neutral or reverse direction.



#### EXCELLENT VISIBILITY

One-piece rounded front glass and large windows around the cab provide the operator with a full 360 degree range of visibility. Wide upper front window good visibility to cutting edge of bucket for loader. Sloped and narrow bonnet is designed for easy and safe work with the front loader.

#### SIDE CONSOLE WITH FULL INSTRUMENTATION

In the DB100 series cab, all gauges switches and levers are conveniently located for easy access. Whether in the loader position or the backhoe position, the operator can easily reach all controls.

# SERVICEABILITY



## QUICK AND EASY MAINTENANCE

Tilt-up hood provides easy access to the engine compartment. The one-piece hood tilts away for easy ground access to all critical services and grease points for maintenance and operator safety.

## INTEGRATED SAFETY BAR

An integrated safety bar and locking pin are an integral part of the bucket cylinder, and guarantee operator safety when servicing.



## VISIBLE HYDRAULIC OIL LEVEL GAUGE

The hydraulic oil sight gauge is installed on the side of the hydraulic tank for the convenient inspection from on ground level.



# TECHNICAL SPECIFICATION

## ENGINE

<b>Model</b>	DEVELON DN03
<b>Horsepower</b>	GROSS POWER : 100 HP (74.5 kW) @ 2,200 rpm 97 HP (72.3 kW) / 2,200 rpm
<b>Type</b>	4-stroke, water cooled turbocharged.
<b>Non-road emission standards</b>	Certified to EPA Tier 4 Final
<b>Max torque</b>	41.6kg·m @ 1,350 rpm
<b>Piston displacement</b>	3.4 ℓ
<b>Fuel</b>	Diesel

## HYDRAULIC SYSTEM

<b>System type</b>	Open center
<b>Pump type</b>	Gear pump
<b>Pump flow</b>	138.4 L/min (Steering + Attachment)
<b>System Pressure</b>	250 kg/cm <sup>2</sup>
<b>Loader valve</b>	- Mechanical control (Base) : 1 Lever - Pilot control (Optional) : 1 Joystick, Boom float, Bucket return to dig
<b>Backhoe valve</b>	- Mechanical control (Base) : 2 Lever - Pilot control : 2 Joysticks Pilot control (Excavator ISO control pattern is standard) Optional pattern change valve for excavator (ISO) control pattern ↔ Backhoe (SAE) control pattern
<b>Stabilizer Control</b>	- Mechanical Control (Base) : 2 Lever - Pilot Control (Option) : 2 small levers - Stabilizer Safety lock valve (Standard)

## ELECTRICAL

<b>Voltage</b>	12 volts
<b>Alternator</b>	140 amp
<b>Battery</b>	1,000 CCA (Standard) = 1 EA

## OPERATING WEIGHTS

<b>Standard configuration</b>	7,440 kg 4 WD, GP bucket (0.8 m <sup>3</sup> ), counter weight (550 kg), ROPS/FOPS canopy, mono dipper
<b>Optional configuration</b>	8,230 kg 4 WD, MP bucket (1.0 m <sup>3</sup> ), counter weight (150 kg), ROPS/FOPS cabin, ext. dipper
<b>Add-on weight</b>	Counter weight 550 kg Drive shaft & T/M under guard 55 kg Fork 170 kg

## TIRES

<b>Front</b>	12.5/80 - 18, 12PR (4WD)
<b>Rear</b>	16.9 - 28, 12PR

## SERVICE REFILL CAPACITIES

<b>Fuel tank</b>	130 ℓ
<b>Engine coolant water</b>	18.5 ℓ
<b>Engine oil with filter</b>	12.6 ℓ
<b>Hyd. tank with filter</b>	50 ℓ
<b>Hyd. system total</b>	93 ℓ
<b>Transmission and torque converter</b>	18 ℓ
<b>Front axle (4 WD)</b>	8 ℓ
<b>Rear axle</b>	16 ℓ

## BACKHOE ATTACHMENTS

<b>Buckets</b>	0.2 m <sup>3</sup> (STD) 0.17 m <sup>3</sup> 0.26 m <sup>3</sup>
<b>Boom</b>	2.63 m (STD) 2.81 m
<b>Arm</b>	2.0 m (STD) 2.0 m ~ 3.12 m

## LOADER BUCKETS

Capacity	Remark	Capacity	Remark
0.8 m <sup>3</sup>	GP BOCE (STD)	0.9 m <sup>3</sup>	GP TOOTH
1.0 m <sup>3</sup>	GP BOCE	1.0 m <sup>3</sup>	MP
0.7 m <sup>3</sup>	GP TOOTH	1.0 m <sup>3</sup>	MP WITH FORK

\* GP : General Purpose, MP : Multi Purpose  
\* BOCE : Bolt on Cutting Edge

## COUNTER WEIGHT

<b>Description</b>	Weight
<b>None, Guard Front</b>	10 kg
<b>Casting, Additional</b>	150 kg
<b>Casting (STD)</b>	350 kg
<b>Casting Additional for Telescopic Arm</b>	550 kg

## POWERTRAIN

<b>Transmission</b>	4-speed helical-cut gears, full powershift standard; electric clutch cutoff on loader lever
<b>Maximum travel speed with standard tire</b>	

DB100	Gear 1	Gear 2	Gear 3	Gear 4
Forward(km/hr)	5.2	9.6	19.4	34.0
Reverse (km/hr) (Optional)	6.6	12.0	(19.0)	N/A

<b>Torque converter</b>	Single stage, dual phase
<b>Differential</b>	Hydraulic locking rear Push-button activation
<b>Steering (Optional)</b>	Hydrostatic power (emergency steering)
<b>Brake</b>	Service - Power assisted, hydraulic wet disc, mounted inboard, self-adjusting and self-equalizing
<b>Parking</b>	- Spring-applied, hydraulically releases, wet, multi disc independent of service brakes with electric switch control

# DIMENSIONS & WORKING RANGE

## DIMENSIONS

All dimensions are approximate.

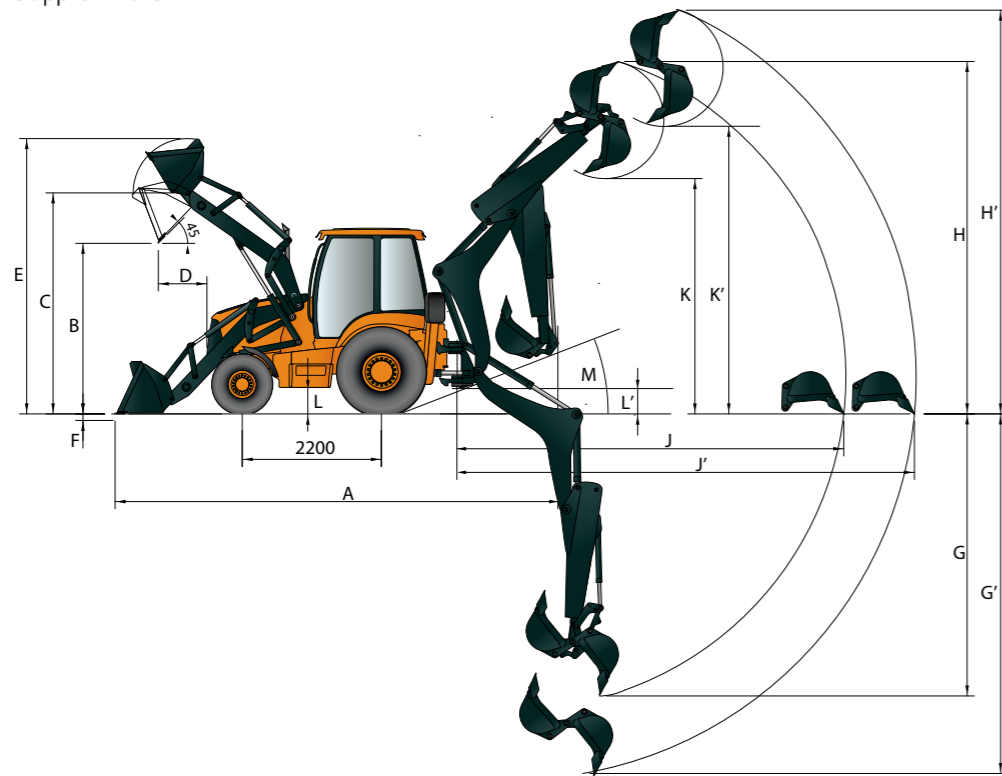

## DESCRIPTION

Dimension	Description	Value (mm / ft-in)
A	Overall length	7,080 (23' 3")
B	Dump clearance	2,710 (8' 11")
C	Hinge pin height	3,450 (11' 4")
D	Dump reach	805 (2' 8")
E	Max loading height	4,230 (13' 11")
F	Depth of bucket down	96 (0' 4")
G	Max digging depth (STD)	4,345 (14' 3")
G'	Max digging depth (EXT)	5,460 (17' 11")

## DESCRIPTION

Unit : mm (ft-in)

Dimension	Description	Value (mm / ft-in)
H	Max digging height (STD)	5,500 (18' 1")
H'	Max digging height (EXT)	6,150 (20' 2")
J	Max digging reach (STD)	5,830 (19' 2")
J'	Max digging reach (EXT)	6,860 (22' 6")
K	Max dumping height (STD)	3,585 (11' 9")
K'	Max dumping height (EXT)	4,230 (13' 11")
L	Minimum ground clearance	261 (0' 10")
L'	Height of outrigger	355 (1' 2")
M	Departure angle	19°

## BUCKETS

	GP Bucket	MP Bucket
Transport length	7,080 (23' 3")	7,210 (23' 8")
Transport height	3,680 (12' 1")	3,680 (12' 5")
Transport width	2,250 (7' 5")	2,300 (7' 7")

## DIGGING FORCE

Description		Unit	Loader	Backhoe
Digging force	Bucket	Kgf	5,800	5,468
	Boom		5,270	3,416

# STANDARD & OPTIONAL

## ENGINE

BASE OPT

DEVELON / DNO3	●	
----------------	---	--

## HYDRAULIC SYSTEM

BASE OPT

Backhoe controls, 2-lever mechanical	●	
Loader controls, 1-lever mechanical	●	
Stabilizer controls, 2-lever mechanical	●	
Fan, suction	●	
Hydraulic hose face seals, o-ring	●	
Hydraulic oil cooler, T/M cooler	●	
Hydraulic valves, loader 3rd Function		●
Hydraulic valves, backhoe 7th Function		●
Hydraulic lines		●
One-way, backhoe breaker line		●
Pilot control (Backhoe, Loader, Stabilizers all together)		●

## CAB & INTERIOR

BASE OPT

Air cleaner	●	
Alarm, back-up	●	
Radio		●
Coolant/Antifreeze	●	
Floor mat	●	
Gauges : coolant temperature, fuel level, tachometer, hour meter	●	
Indicators: Engine oil pressure, T/M oil temp, diff. lock, coolant temp, fuel level, battery charge, air cleaner, high beam, parking	●	
Instrument panel lights	●	
Seat belt, retractable (51 mm / 2 in)	●	
Seat, suspension with armrest	●	
Storage compartment, internal	●	
Throttles, hand and foot	●	
Transmission neutralizer button switch	●	
Air conditioner & Heater		●
Air conditioner only	●	
Fuel warmer		●
Speed meter	●	
Climate control system		●
Cabin ROPS / FOPS		●
Canopy ROPS / FOPS		●
Canopy ROPS / FOPS with front shield		●

## SAFETY

BASE OPT

Differential lock	●	
Brakes, oil disc, dual pedals, interlocking	●	
Flashing hazard/signal lights	●	
Working lights (2 front, 2 rear)	●	
Machine security system	●	
Mirror, rear view	●	
Parking brake	●	
Stop and tail lights	●	
Swing transport lock	●	
Warning horn, electric	●	
Grill guard bumper		●
Front drive shaft guards		●
Work lights(4 front, 4 rear)		●
Rotating beacon		●
Power boosted brake	●	
Pilot control safety system	●	
Clam safety system		●

## ATTACHMENT

BASE OPT

Stabilizers (Pad for street)		●
Backhoe		
Buckets	0.2 m <sup>3</sup> (0.26 yd <sup>3</sup> )	●
	0.17 m <sup>3</sup> (0.22 yd <sup>3</sup> )	●
	0.26 m <sup>3</sup> (0.34 yd <sup>3</sup> )	●
Boom	2.63 m for Heavy duty	●
	2.81 m	●
Dipper	2.00 m ~3.12 m (Telescopic)	●
	2.00 m	●
Front loader		
General purpose buckets	0.8 m <sup>3</sup> (1.04 yd <sup>3</sup> ) - Bolt-on cutting edge	●
	0.7 m <sup>3</sup> (0.92 yd <sup>3</sup> ) - Bolt-on teeth	●
	0.9 m <sup>3</sup> (1.18 yd <sup>3</sup> ) - Bolt-on teeth	●
	1.0 m <sup>3</sup> (1.31 yd <sup>3</sup> ) - Bolt-on cutting edge	●
Multi purpose buckets	1.0 m <sup>3</sup> (1.3 yd <sup>3</sup> )	●
	1.0 m <sup>3</sup> (1.3 yd <sup>3</sup> ) w/ forks	●

## OTHER

BASE OPT

Battery, maintenance-free, 1000 CCA x 1		●
Battery disconnect switch		●
Filters, spin-on		●
Fuel prefilter with water separator		●
Glow plug (cold starting aid)		●
Ground level fuel fill		●
Power receptacle, 12V		●
Power steering, hydrostatic		●
Emergency steering		●
Toolbox, external, lockable		●
Torque converter		●
Transmission :		
Power shift, 4 forward, 2 reverse, 2 wheel drive		●
Transmission :		
Power shift, 4 forward, 3 reverse, 4 wheel drive		●
Boom transport lock - Backhoe (Cylinder)		●
Boom locking bar - Loader		●
Mechanical quick coupler		●
Swing damper		●
Counter weights	Guard front, 10 kg (22 lb)	●
	Casting, 150 kg (331 lb)	●
	Casting, 350 kg (772 lb)	●
	Casting additional for telescopic arm, 550 kg (1,213 lb)	●
Return-to-dig, loader		●
Ride control, loader		●
Control pattern selector		●

## UNDERCARRIAGE

BASE OPT

Fenders, rear		●
Tilt steering wheel		●
Tire(Front) : 11L-165L, 12PR(2WD, ATG)		●
Tire(Rear) : 19.5-24, 12PR(ATG)		●
Fenders, 4WD, front		●
Tire(Front) : 12.5/80-18,12PR(4WD, ATG)		●
Tire(Rear) : 16.9-28,12PR(ATG)		●

\* Standard and optional equipment may vary. Contact your DEVELON dealer for more information. The machine may vary according to International standards.

\* The photos may include attachments and optional equipment that are not available in your area.

\* Materials and specifications are subject to change without advance notice.

\* All imperial measurements rounded off to the nearest pound or inch.